

■ Introduction

Vee-Lok tube fittings are designed to provide a leak-free connection and applied in chemical, petrochemical, oil refineries, shipbuilding, power generation and pulp and papers. The double ferrule design is a mechanism used for sealing and gripping tubing. Through the mechanical advantage and geometry, the tube fitting can overcome the variations in materials, wall thickness and hardness to provide an excellent seal performance.

The tube fitting consists of four parts: body, front ferrule, back ferrule and nut. The two ferrules separate sealing and tube gripping function and achieve excellent leak-free performance.

■ Features

When the nut is tightened, the back and front ferrules move axially. The axial movement does not allow any torque transfer from the fitting to tubing and the mechanical properties of tubing are maintained. The front ferrule creates a seal against the fitting body and on the tubing outside diameter while the back ferrule axially advances the front ferrule and radially provides an effective tube grip.

■ Material

Vee-Lok twin ferrule tube fittings are made of 316 stainless steel and supplied in metric and imperial sizes from 6mm O.D. to 25mm O.D. and 1/8"O.D. to 1"O.D. Straight fittings are machined from bar stock conforming to ASTM A276, ASME SA479, ASTM A479 and shaped bodies from forging ASME SA182 and ASTM A182.

■ Easy Reference

Heads of tables are differentiated with color below:

 Identifies fractional size

 Identifies metric size

■ Pressure Ratings

The pressure ratings of the Vee-Lok tube fittings are determined by the wall thicknesses of tubings on which they are installed. The maximum working pressure of tubings are listed in MAWP Table on following page.



Note:

Material strength and allowable working pressure decrease as the temperature increases

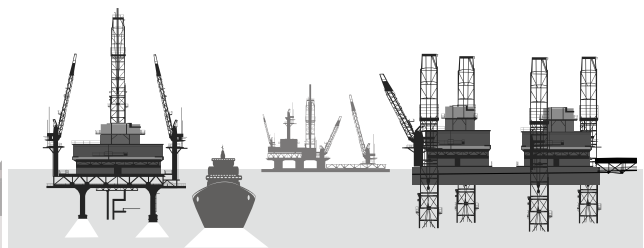

■ Temperature Ratings

316 stainless steel: -321°F to 1200°F (-196°C to 649°C)

■ Tubing

In order to ensure reliable and leak-free installation, tubing should be considered as one of fitting components.

■ Tubing Selection

Hardness

- The metal tubing must be softer than the fitting materials. In general, it is recommended a fully annealed 304 or 316 stainless steel tubing meeting ASTM A269 or equivalent with hardness Rockwell HRB80 or less to work properly with VEE-LOK tube fittings.

Surface

- Tubing must have a smooth surface free from dirt, scratches, weld seam and draw mark.

Ovality

- Do not force the tubing into the fitting when tubing is oval or out of roundness. It may damage the fitting sealing mechanism on nut, ferrules and body.

Wall thickness

- Temperature, pressure, vibration and shock conditions must be considered when selecting the wall thickness. A too thin wall may collapse and too thick wall may not be properly deformed by ferrule action.

Tubing Handling

- Tubing ends should be capped to keep from dirt during transportation and storage.
- Do use correct tube cutter to avoid excessive deformation.
- Do deburr tube ends prior to installation.

Use good quality tubing for the best performance.

■ Gas Application

Gases have very small molecules and can escape even the most minute leak path because of surface imperfections.

Do not use thin wall tubing for gas applications. Heavier wall tubing resists the ferrule action more than thin wall does. The minimum wall thickness for gas application is shown for reference.

■ HIGH PRESSURE APPLICATION

Due to the variation of tubing diameters, a common starting point is desirable. Therefore, with a wrench, snug up the nut until the tubing will not turn by hand or move axially in the fitting. At this point, scribe or mark the nut on the fitting. Using the scribe or mark on the nut to keep track of the turns, tighten the nut 1 1/4 turns while holding the body stationary with a backup wrench. Only you can determine what is "high pressure" or "high safety factor" service. Using "1 1/4 turns from snug" merely does away with one variable because the ferrules are in definite contact with the tube when you start the pull-up.

■ Fractional Tubing

Tubing O.D.	Nominal Min. Wall Thickness	Tubing O.D.	Nominal Min. Wall Thickness
1/8"	0.028"	1/2"	0.049"
1/4"	0.028"	5/8"	0.065"
5/16"	0.035"	3/4"	0.065"
3/8"	0.035"	1"	0.083"

■ Metric Tubing

Tubing O.D.	Nominal Min. Wall Thickness	Tubing O.D.	Nominal Min. Wall Thickness
6mm	0.8mm	16mm	1.5mm
8mm	1.0mm	18mm	1.5mm
10mm	1.0mm	20mm	1.8mm
12mm	1.0mm	22mm	2.0mm
15mm	1.2mm	25mm	2.2mm

■ Temperature Derating

The working pressure varies depending on temperature. The working pressure at various temperatures can be obtained by multiplying the working pressure at ambient temperature (-20°F to 100°F or -29°C to 37°C) by the temperature derating factor in the table below.

Temperature (°F)	316 SS
100	1.00
200	1.00
300	1.00
400	0.96
500	0.90
600	0.85
700	0.82
800	0.79
900	0.78
1000	0.76
1100	0.62
1200	0.37

■ Example

To obtain the working pressure of 316SS 1/4"O.D. x 0.035" wall tube at 800°F

- Working pressure of the above tubing at ambient temperature: 5,100 psi
- Temperature derating factor at 800°F: 0.79
- Working pressure at 800°F: 4,029 psi (from 5,100 psi multiplied by 0.79)

■ Maximum Allowable Working Pressure Table

Fully annealed austenitic type 304 or 316 seamless tubing ASTM A269 or ASTM A213, or equivalent. Tubing to be free from dirt, scratches, weld seam, draw mark and suitable for bending and flaring. Recommended hardness: 80 HRB or less.

Stainless Steel Tube Inch Size				
Tube O.D. (Inches)	Tube Wall Thickness in Inches			
	0.035	0.049	0.065	0.083
1/8"	10,900			
1/4"	5,100	7,500	10,200	Working Pressure in psig
5/16"	4,000	5,800	8,000	
3/8"	3,300	4,800	6,500	
1/2"	2,600	3,700	5,100	6,700
3/4"	For gas service, applying the wall thickness only on outside of shade boundary	2,400	3,300	4,200
7/8"		2,000	2,800	3,600
1"			2,400	3,100

Stainless Steel Tube Metric Size							
Tube O.D. (mm)	Tube Wall Thickness in Millimeters						
	0.89	1.00	1.24	1.50	1.65	2.00	2.20
6	6,500	7,400	9,400	11,500	12,700	Working Pressure in psig	
8	4,700	5,800	6,800	8,400	9,300		
10	3,700	4,200	5,300	6,500	7,300		
12	3,000	3,400	4,400	5,300	5,900	6,600	7,000
16		2,500	3,200	3,900	4,300	5,300	5,700
18	For gas service, applying the wall thickness only on outside of shade boundary		2,800	3,400	3,800	4,700	5,000
20			2,500	3,000	3,400	4,200	4,400
22			2,300	2,800	3,000	3,800	4,000
25			2,000	2,400	2,700	3,300	3,500

- Allowable stress of 20,000 psi between -20°F and 100°F (-29°C and 37°C) based on ultimate tensile strength 75,000 psi
- Based on minimum wall thickness and maximum O.D. allowable by ASTM A269

Note:

1. Pressure calculations are based on maximum O.D. and minimum wall thickness without allowance for corrosion and erosion.
2. Figures shown are not for design purpose but for reference only. The accuracy of information here is not liability of our company.

■ Identification of Metric Size

Metric tube fittings are machined with the stepped shoulders on the body and the hex nut for identification. The metric nut must not be used on fractional body, and vice versa.



■ Sealing

Taper Thread

NPT, BSPT (BS21) and ISO7/1 taper threads must use a thread sealant and proper lubrication to provide leak-free connection and prevent from galling that is mostly common in stainless steel.

ISO Parallel Thread

With ISO 228/1, BSPP (BS2779) parallel thread requires a sealing washer. This seal may either be a metal (copper is standard) gasket or a “Bonded Seal” (elastomer bonded to a metal retaining washer). See 2 different seals below.

Form A

No reverse angle is used. A self centering taper is used at hex which centers a “Bonded” washer seal (usually metal and elastomer” to seal the surface surrounding the female thread.

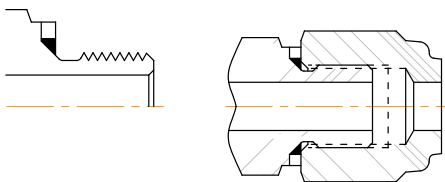

Form B

A metal gasket (usually copper) gasket performs the sealing between the face of body and the surface surrounding the female threads.

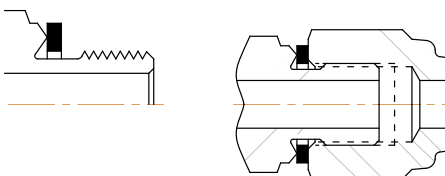

■ Installation Instructions

VEE-LOK two ferrule tube fittings are supplied finger tight and ready for immediate use. A leak tight and mechanically safe installation is easily made by turning the nut 1.1/4 turns or 3/4 turn for a smaller size in 1/8” O.D.

Prior to installation, make sure to have tube end cut 90 degree and remove burrs from inside and outside tube ends.

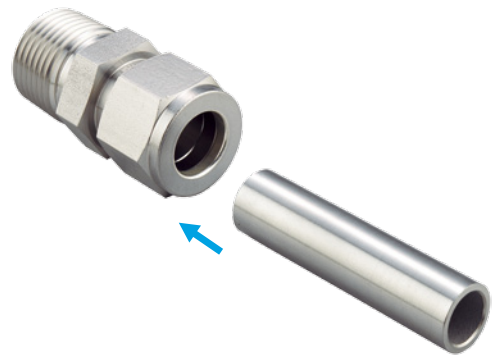

1. Insert well prepared tubing into VEE-LOK two ferrule tube fittings until tubing end is firmly seated on the body shoulder.

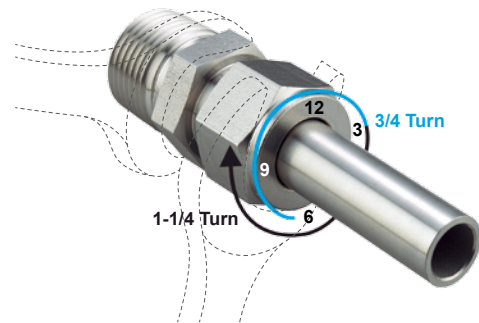

2. Mark the nut at position no.6 for identification of starting point to count the number of turns.
3. When holding the fitting body with a wrench to prevent the body from turning, tighten the nut with another wrench 1.1/4 turns to position no.9.

Note:

It is the responsibility of users to use the products for their specific application and adequately apply sealant and lubrication to system installation.

Improper installation or intermixing components of other manufacturers may cause personal injury or property losses.

Ordering Information

Example 1: Tube to Pipe ends

M MC 8- 4 BSPT
① ② ③ ④ ⑤

- ① "M" is prefixed to designate metric VEE-LOK tube fittings. Fractional size remains blank.
- ② Name of Fitting (MC=Male Connector)
- ③ Tube O.D. Designator
- ④ Pipe Thread Designator
- ⑤ "BSPT" or "BSPP" is to specify thread type. NPT thread remains blank.

Example 2: Tube to Tube ends

M U 6
① ② ③

- ① "M" is prefixed to designate metric VEE-LOK tube fittings.
- ② Name of Fitting (U=Union)
- ③ Tube O.D. Designator

Example 3: Tee & Cross

In tee shown below, "1" and "2" are referred to as run and "3" is referred to as branch.

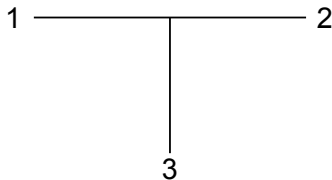

In cross shown below, "1" and "2" are referred to as run and "3" and "4" are referred to as branch.

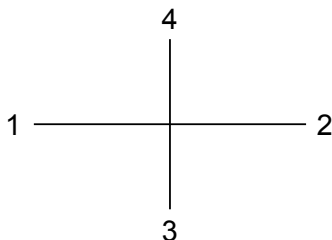

Fitting Name Designator	
Identifier	Description
MC	Male Connector
BMC	Bulkhead Male Connector
ME	Male Elbow
MRT	Male Run Tee
MBT	Male Branch Tee
UT	Union Tee
U	Union
RU	Reducing Union
BU	Bulkhead Union
UE	Union Elbow
UC	Union Cross
FC	Female Connector
BFC	Bulkhead Female Connector
FE	Female Elbow
FRT	Female Run Tee
FBT	Female Branch Tee
R	Reducer
MA	Male Adapter
FA	Female Adapter
N	Nut
BF	Back Ferrule
FF	Front Ferrule
P	Plug
CP	Cap

Tube O.D. Designator			
Inch O.D.	Identifier	Metric O.D.	Identifier
1/8	1	6	6
1/4	4	8	8
5/16	5	10	10
3/8	6	12	12
1/2	8	16	16
3/4	12	20	20
1	16	25	25

Pipe Thread Designator							
Nominal Size	1/8"	1/4"	3/8"	1/2"	3/4"	1"	Applicable Specifications
NPT	2	4	6	8	12	16	ANSI B1.20.1 (NPT)
ISO Tapered	2BSPT	4BSPT	6BSPT	8BSPT	12BSPT	16BSPT	BS 21(BSPT), ISO7/1, JIS B0203(PT)
ISO Parallel	2BSPP	4BSPP	6BSPP	8BSPP	12BSPP	16BSPP	BS 2779 (BSPP), DIN ISO 228/1, JIS B0202(PF)

Index

General Information 01~04

Ordering Information 05

Tube to Male Pipe

Male Connector
MC 07~08



Bulkhead Male Connector
BMC 09



Male Elbow
ME 10~11



Male Run Tee
MRT 12



Male Branch Tee
MBT 13



Tube to Female Pipe

Female Connector
FC 14



Bulkhead Female Connector
BFC 15



Female Elbow
FE 16



Female Run Tee
FRT 17



Female Branch Tee
FBT 18



Tube to Tube Union

Union Tee
UT 19



Union
U 20



Reducing Union
RU 21



Bulkhead Union
BU 22



Union Elbow
UE 23



Cross Union
CU 24



Port Connector

Reducer
R 25~26



Male Adapter
MA 27



Female Adapter
FA 28



Component

Nut
N 29



Back Ferrule
BF 30



Front Ferrule
FF 31



Plug
P 32



Cap
CP



MALE CONNECTOR

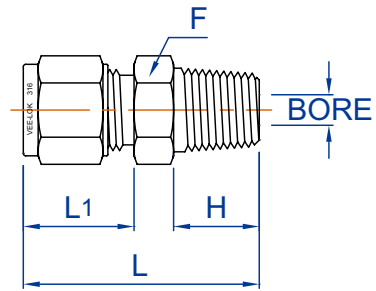

TUBE O.D.	MALE THREAD	PART NO.	L	L1	H	F	BORE
INCHES							
1/16	1/16	MC1-1	0.930	0.430	0.380	5/16	0.052
1/16	1/8	MC1-2	1.030	0.430	0.380	7/16	0.052
1/16	1/4	MC1-4	1.230	0.430	0.560	9/16	0.052
1/8	1/8	MC2-2	1.204	0.594	0.381	7/16	0.094
1/8	1/4	MC2-4	1.401	0.594	0.559	9/16	0.094
1/8	3/8	MC2-6	1.417	0.594	0.559	11/16	0.094
1/8	1/2	MC2-8	1.669	0.594	0.751	7/8	0.094
1/4	1/8	MC4-2	1.293	0.697	0.381	1/2	0.196
1/4	1/4	MC4-4	1.494	0.697	0.559	9/16	0.196
1/4	3/8	MC4-6	1.514	0.697	0.559	11/16	0.196
1/4	1/2	MC4-8	1.762	0.697	0.751	7/8	0.196
1/4	3/4	MC4-12	1.825	0.697	0.751	1-1/16	0.196
5/16	1/8	MC5-2	1.336	0.730	0.381	9/16	0.196
5/16	1/4	MC5-4	1.525	0.730	0.559	9/16	0.255
5/16	3/8	MC5-6	1.513	0.730	0.559	11/16	0.255
3/8	1/8	MC6-2	1.380	0.758	0.381	5/8	0.196
3/8	1/4	MC6-4	1.569	0.758	0.559	5/8	0.279
3/8	3/8	MC6-6	1.569	0.758	0.559	11/16	0.279
3/8	1/2	MC6-8	1.821	0.758	0.751	7/8	0.279
3/8	3/4	MC6-12	1.864	0.758	0.751	1-1/16	0.279
1/2	1/8	MC8-2	1.518	0.857	0.381	13/16	0.196
1/2	1/4	MC8-4	1.700	0.857	0.559	13/16	0.279
1/2	3/8	MC8-6	1.700	0.857	0.559	13/16	0.374
1/2	1/2	MC8-8	1.920	0.857	0.751	7/8	0.409
1/2	3/4	MC8-12	1.979	0.857	0.751	1-1/16	0.409
1/2	1	MC8-16	2.262	0.857	0.940	1-3/8	0.409
5/8	3/8	MC10-6	1.707	0.865	0.559	1-5/16	0.374
5/8	1/2	MC10-8	1.928	0.865	0.751	1-5/16	0.468
5/8	3/4	MC10-12	1.987	0.865	0.751	1-1/16	0.500
3/4	1/2	MC12-8	1.983	0.857	0.751	1-1/16	0.468
3/4	3/4	MC12-12	1.983	0.857	0.751	1-1/16	0.610
3/4	1	MC12-16	2.270	0.857	0.940	1-3/8	0.610
1	1/2	MC16-8	2.264	1.043	0.751	1-3/8	0.468
1	3/4	MC16-12	2.264	1.043	0.751	1-3/8	0.610
1	1	MC16-16	2.453	1.043	0.940	1-3/8	0.866

Dimensions for reference only, subject to change without prior notice

MALE CONNECTOR

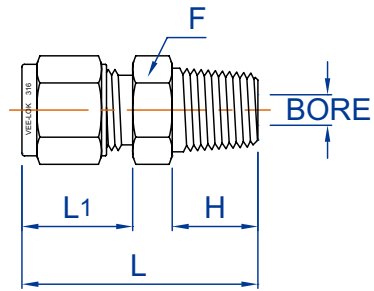

TUBE O.D.	MALE THREAD	PART NO.	L	L1	H	F	BORE
MILLIMETERS							
6	1/8	MMC6-2	33.10	17.80	9.50	14	5.00
6	1/4	MMC6-4	38.40	17.80	14.20	14	5.00
6	3/8	MMC6-6	38.50	17.80	14.20	18	5.00
6	1/2	MMC6-8	44.80	17.80	19.10	22	5.00
8	1/8	MMC8-2	34.10	18.50	9.50	15	5.00
8	1/4	MMC8-4	38.70	18.50	14.20	15	6.50
8	3/8	MMC8-6	39.20	18.50	14.20	18	6.50
8	1/2	MMC8-8	45.50	18.50	19.10	22	6.50
10	1/8	MMC10-2	36.40	19.60	9.50	18	5.00
10	1/4	MMC10-4	41.00	19.60	14.20	18	7.10
10	3/8	MMC10-6	41.00	19.60	14.20	18	7.90
10	1/2	MMC10-8	46.60	19.60	19.10	22	7.90
10	3/4	MMC10-12	46.60	19.60	19.10	27	7.90
12	1/4	MMC12-4	43.21	21.81	14.20	22	7.10
12	3/8	MMC12-6	43.21	21.81	14.20	22	9.50
12	1/2	MMC12-8	48.81	21.81	19.10	22	9.50
12	3/4	MMC12-12	50.31	21.81	19.10	27	9.50
14	1/4	MMC14-4	44.00	21.81	14.20	24	7.10
14	3/8	MMC14-6	44.00	21.81	14.20	24	9.50
14	1/2	MMC14-8	48.80	21.81	19.10	24	11.10
15	1/2	MMC15-8	48.80	21.81	19.10	24	11.90
16	3/8	MMC16-6	44.00	21.81	14.20	24	9.50
16	1/2	MMC16-8	48.80	21.81	19.10	24	11.90
16	3/4	MMC16-12	50.40	21.81	19.10	27	12.70
18	1/2	MMC18-8	50.40	21.81	19.10	27	11.90
18	3/4	MMC18-12	50.40	21.81	19.10	27	15.00
20	1/2	MMC20-8	52.10	21.83	19.10	30	11.90
20	3/4	MMC20-12	52.10	21.83	19.10	30	15.50
22	3/4	MMC22-12	52.10	21.81	19.10	30	15.50
25	1/2	MMC25-8	57.80	26.76	19.10	35	11.90
25	3/4	MMC25-12	58.06	26.76	19.10	35	15.50
25	1	MMC25-16	63.06	26.76	23.90	35	22.00

Dimensions for reference only, subject to change without prior notice

BULKHEAD MALE CONNECTOR

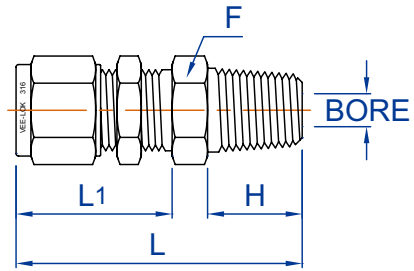

TUBE O.D.	MALE THREAD	PART NO.	L	L1	H	F	Panel Hole Size	Max. Panel Thick.	BORE
INCHES									
1/16	1/16	BMC1-1	1.190	0.68	0.38	5/16	13/64	0.12	0.052
1/16	1/8	BMC1-2	1.270	0.68	0.38	7/16	13/64	0.12	0.052
1/8	1/8	BMC2-2	1.830	1.23	0.38	1/2	21/64	0.50	0.09
1/4	1/8	BMC4-2	1.950	1.31	0.38	5/8	29/64	0.40	0.20
1/4	1/4	BMC4-4	2.132	1.31	0.56	5/8	29/64	0.40	0.20
3/8	1/4	BMC6-4	2.265	1.44	0.56	3/4	37/64	0.44	0.28
3/8	3/8	BMC6-6	2.265	1.44	0.56	3/4	37/64	0.44	0.28
3/8	1/2	BMC6-8	2.480	1.44	0.75	7/8	37/64	0.44	0.28
1/2	3/8	BMC8-6	2.494	1.65	0.56	15/16	49/64	0.50	0.38
1/2	1/2	BMC8-8	2.712	1.65	0.75	15/16	49/64	0.50	0.41
3/4	3/4	BMC12-12	3.000	1.87	0.75	1-3/16	1-1/64	0.66	0.61
1	1	BMC16-16	3.720	2.27	0.94	1-5/8	1-21/64	0.75	0.86

TUBE O.D.	MALE THREAD	PART NO.	L	L1	H	F	Panel Hole Size	Max. Panel Thick.	BORE
MILLIMETERS									
6	1/8	MBMC6-2	49.60	33.70	9.50	16	11.50	10.20	5.00
6	1/4	MBMC6-4	53.50	33.70	14.30	16	11.50	10.20	5.00
8	1/8	MBMC8-2	52.30	36.00	9.50	18	13.10	11.20	6.50
8	1/4	MBMC8-4	57.50	36.00	14.30	18	13.10	11.20	7.90
10	1/4	MBMC10-4	58.40	37.00	14.30	22	16.30	11.20	7.90
10	3/8	MBMC10-6	58.40	37.00	14.30	22	16.30	11.20	7.90
10	1/2	MBMC10-8	63.10	37.00	19.00	22	16.30	11.20	7.90
12	1/4	MBMC12-4	63.30	10.10	14.30	24	19.50	12.70	7.10
12	3/8	MBMC12-6	64.50	10.10	14.30	24	19.50	12.70	9.50
12	1/2	MBMC12-8	67.50	10.10	19.00	24	19.50	12.70	9.50

Dimensions for reference only, subject to change without prior notice

MALE ELBOW

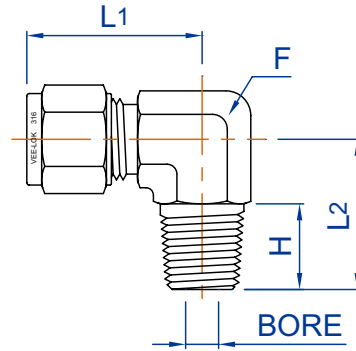

TUBE O.D.	MALE THREAD	PART NO.	L1	L2	H	F	BORE
INCHES							
1/16	1/16	ME1-1	0.75	0.71	0.38	1/2	0.052
1/16	1/8	ME1-2	0.75	0.71	0.38	1/2	0.052
1/8	1/8	ME2-2	1.07	0.70	0.38	1/2	0.09
1/8	1/4	ME2-4	1.07	0.95	0.56	1/2	0.09
1/4	1/8	ME4-2	1.08	0.70	0.38	1/2	0.20
1/4	1/4	ME4-4	1.08	0.95	0.56	1/2	0.20
1/4	3/8	ME4-6	1.16	1.10	0.56	5/8	0.20
1/4	1/2	ME4-8	1.31	1.35	0.75	13/16	0.20
5/16	1/8	ME5-2	1.14	0.77	0.38	9/16	0.20
5/16	1/4	ME5-4	1.14	1.01	0.56	9/16	0.25
3/8	1/8	ME6-2	1.20	0.79	0.38	5/8	0.20
3/8	1/4	ME6-4	1.20	0.97	0.56	5/8	0.28
3/8	3/8	ME6-6	1.20	1.10	0.56	5/8	0.28
3/8	1/2	ME6-8	1.36	1.35	0.75	13/16	0.28
3/8	3/4	ME6-12	1.48	1.50	0.75	1	0.28
1/2	1/4	ME8-4	1.44	1.15	0.56	13/16	0.28
1/2	3/8	ME8-6	1.44	1.15	0.56	13/16	0.38
1/2	1/2	ME8-8	1.44	1.35	0.75	13/16	0.41
1/2	3/4	ME8-12	1.58	1.51	0.75	1	0.41
5/8	3/8	ME10-6	1.60	1.31	0.56	1	0.38
5/8	1/2	ME10-8	1.60	1.50	0.75	1	0.47
5/8	3/4	ME10-12	1.60	1.51	0.75	1	0.50
3/4	1/2	ME12-8	1.60	1.50	0.75	1	0.47
3/4	3/4	ME12-12	1.60	1.51	0.75	1	0.61
1	3/4	ME16-12	1.99	1.81	0.75	1-3/8	0.61
1	1	ME16-16	1.99	1.89	0.94	1-3/8	0.86

Dimensions for reference only, subject to change without prior notice

MALE ELBOW

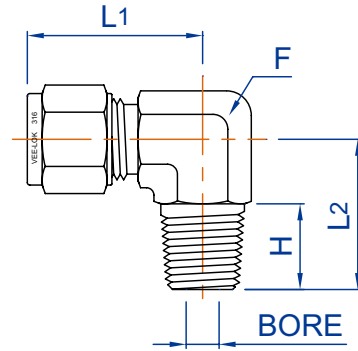

TUBE O.D.	MALE THREAD	PART NO.	L1	L2	H	F	BORE
MILLIMETERS							
6	1/8	MME6-2	27.20	17.70	9.70	1/2	5.00
6	1/4	MME6-4	27.20	24.10	14.20	1/2	5.00
6	3/8	MME6-6	29.50	28.00	14.20	5/8	5.00
6	1/2	MME6-8	33.20	34.20	19.00	13/16	5.00
8	1/8	MME8-2	29.00	19.70	9.70	9/16	5.00
8	1/4	MME8-4	29.00	25.80	14.20	9/16	6.50
8	3/8	MME8-6	29.75	28.00	14.20	5/8	6.50
8	1/2	MME8-8	35.40	34.20	19.10	13/16	6.50
10	1/8	MME10-2	31.50	22.10	9.70	11/16	5.00
10	1/4	MME10-4	31.50	26.60	14.20	11/16	7.10
10	3/8	MME10-6	31.50	26.60	14.20	11/16	7.90
10	1/2	MME10-8	34.40	34.20	19.00	13/16	7.90
12	1/4	MME12-4	36.60	29.10	14.20	13/16	7.10
12	3/8	MME12-6	36.60	29.10	14.20	13/16	9.50
12	1/2	MME12-8	36.60	34.20	19.00	13/16	9.50
12	3/4	MME12-12	40.20	38.40	19.00	1	9.50
15	1/2	MME15-8	40.50	38.00	19.00	1	11.90
16	3/8	MME16-6	40.50	33.40	14.20	1	9.50
16	1/2	MME16-8	40.50	38.00	19.00	1	11.90
16	3/4	MME16-12	40.50	38.40	19.00	1	12.70
18	1/2	MME18-8	40.50	38.00	19.00	1	11.90
18	3/4	MME18-12	40.50	38.40	19.00	1	15.00
20	1/2	MME20-8	47.50	46.00	19.00	1-3/8	11.90
20	3/4	MME20-12	47.50	46.00	19.00	1-3/8	16.00
22	3/4	MME22-12	47.50	46.00	19.00	1-3/8	16.00
25	3/4	MME25-12	50.70	46.00	19.00	1-3/8	16.00
25	1	MME25-16	50.71	48.00	23.90	1-3/8	22.00

Dimensions for reference only, subject to change without prior notice

MALE RUN TEE

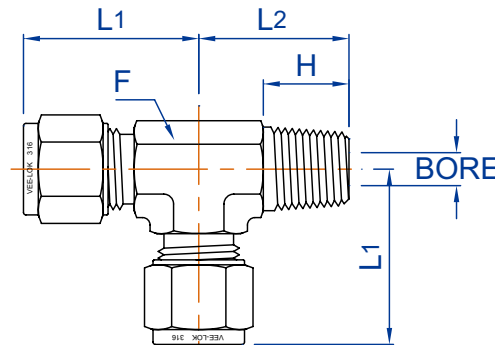

TUBE O.D.	MALE THREAD	PART NO.	L1	L2	H	F	BORE
INCHES							
1/8	1/8	MRT2-2	1.09	0.71	0.38	1/2	0.09
1/8	1/4	MRT2-4	1.04	0.96	0.56	1/2	0.09
1/4	1/8	MRT4-2	1.07	0.72	0.38	1/2	0.20
1/4	1/4	MRT4-4	1.06	0.96	0.56	1/2	0.20
5/16	1/8	MRT5-2	1.16	0.82	0.38	5/8	0.20
3/8	1/4	MRT6-4	1.20	0.95	0.56	5/8	0.28
3/8	3/8	MRT6-6	1.18	1.11	0.56	5/8	0.28
1/2	3/8	MRT8-6	1.44	1.15	0.56	13/16	0.38
1/2	1/2	MRT8-8	1.44	1.40	0.75	7/8	0.41
5/8	1/2	MRT10-8	1.59	1.50	0.75	1-1/16	0.47
3/4	3/4	MRT12-12	1.59	1.50	0.75	1-1/16	0.61
1	3/4	MRT16-12	2.00	1.81	0.75	1-3/8	0.61
1	1	MRT16-16	2.00	1.89	0.94	1-3/8	0.86

TUBE O.D.	MALE THREAD	PART NO.	L1	L2	H	F	BORE
MILLIMETERS							
6	1/8	MMRT6-2	27.20	18.30	9.70	1/2	5.00
6	1/4	MMRT6-4	26.70	24.30	14.20	1/2	5.00
8	1/8	MMRT8-2	29.50	20.80	9.70	5/8	5.00
8	1/4	MMRT8-4	29.50	24.70	14.20	5/8	6.50
10	1/4	MMRT10-4	31.60	26.40	14.20	11/16	7.10
10	1/2	MMRT10-8	34.40	35.30	19.00	7/8	7.90
12	1/4	MMRT12-4	36.60	29.10	14.20	13/16	7.10
12	3/8	MMRT12-6	36.60	29.10	14.20	13/16	9.50
12	1/2	MMRT12-8	36.60	35.50	19.00	7/8	9.50
16	1	MMRT16-16	47.90	48.00	23.90	1-3/8	12.70

Dimensions for reference only, subject to change without prior notice

MALE BRANCH TEE

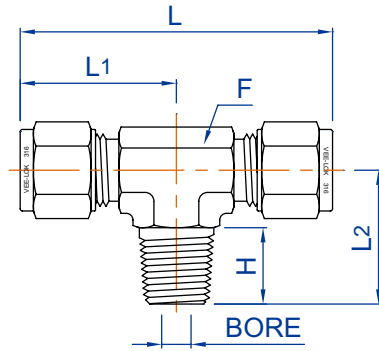

TUBE O.D.	MALE THREAD	PART NO.	L	L1	L2	H	F	BORE
INCHES								
1/8	1/8	MBT2-2	2.18	1.09	0.71	0.38	1/2	0.09
1/8	1/4	MBT2-4	2.08	1.04	0.96	0.56	1/2	0.09
1/4	1/8	MBT4-2	2.14	1.07	0.72	0.38	1/2	0.20
1/4	1/4	MBT4-4	2.12	1.06	0.96	0.56	1/2	0.20
5/16	1/8	MBT5-2	2.32	1.16	0.82	0.38	5/8	0.20
3/8	1/4	MBT6-4	2.40	1.20	0.97	0.56	5/8	0.28
3/8	3/8	MBT6-6	2.36	1.18	1.11	0.56	5/8	0.28
1/2	3/8	MBT8-6	2.88	1.44	1.15	0.56	13/16	0.38
1/2	1/2	MBT8-8	2.88	1.44	1.40	0.75	7/8	0.41
5/8	1/2	MBT10-8	3.18	1.59	1.50	0.75	1-1/16	0.47
3/4	3/4	MBT12-12	3.18	1.59	1.50	0.75	1-1/16	0.61

TUBE O.D.	MALE THREAD	PART NO.	L	L1	L2	H	F	BORE
MILLIMETERS								
6	1/8	MMBT6-2	54.40	27.20	18.00	9.70	1/2	5.00
6	1/4	MMBT6-4	53.40	26.70	24.30	14.20	1/2	5.00
8	1/8	MMBT8-2	59.00	29.50	20.80	9.70	5/8	5.00
8	1/4	MMBT8-4	59.00	29.50	24.70	14.20	5/8	6.50
10	1/4	MMBT10-4	63.20	31.60	26.40	14.20	11/16	7.10
10	3/8	MMBT10-6	63.20	31.60	26.40	14.20	11/16	7.90
12	1/4	MMBT12-4	73.20	36.60	29.10	14.20	13/16	7.10
12	3/8	MMBT12-6	73.20	36.60	29.10	14.20	13/16	9.50
12	1/2	MMBT12-8	73.20	36.60	35.50	19.00	7/8	9.50
16	1/2	MMBT16-8	81.00	40.50	38.00	19.10	1-1/16	11.90

Dimensions for reference only, subject to change without prior notice

FEMALE CONNECTOR

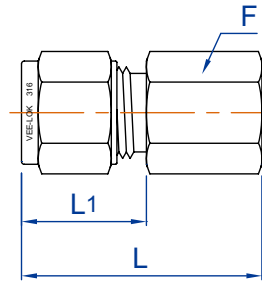

TUBE O.D.	FEMALE THREAD	PART NO.	L	L1	F	BORE
INCHES						
1/16	1/16	FC1-1	0.93	0.43	7/16	0.052
1/16	1/8	FC1-2	0.95	0.43	9/16	0.052
1/8	1/8	FC2-2	1.15	0.60	9/16	0.09
1/8	1/4	FC2-4	1.35	0.60	3/4	0.09
1/4	1/8	FC4-2	1.25	0.70	9/16	0.20
1/4	1/4	FC4-4	1.44	0.70	3/4	0.20
1/4	3/8	FC4-6	1.48	0.70	7/8	0.20
1/4	1/2	FC4-8	1.64	0.70	1-1/16	0.20
5/16	1/8	FC5-2	1.28	0.73	9/16	0.25
5/16	1/4	FC5-4	1.47	0.73	3/4	0.25
3/8	1/8	FC6-2	1.31	0.76	5/8	0.28
3/8	1/4	FC6-4	1.51	0.76	3/4	0.28
3/8	3/8	FC6-6	1.54	0.76	7/8	0.28
3/8	1/2	FC6-8	1.70	0.76	1-1/16	0.28
3/8	3/4	FC6-12	1.82	0.76	1-3/8	0.28
1/2	1/4	FC8-4	1.60	0.87	13/16	0.41
1/2	3/8	FC8-6	1.64	0.87	7/8	0.41
1/2	1/2	FC8-8	1.80	0.87	1-1/16	0.41
1/2	3/4	FC8-12	1.92	0.87	1-3/8	0.41
5/8	3/8	FC10-6	1.65	0.87	15/16	0.50
5/8	1/2	FC10-8	1.81	0.87	1-1/16	0.50
5/8	3/4	FC10-12	1.92	0.87	1-3/8	0.50
3/4	1/2	FC12-8	1.80	0.87	1-1/16	0.61
3/4	3/4	FC12-12	1.92	0.87	1-3/8	0.61
1	3/4	FC16-12	2.10	1.05	1-3/8	0.86
1	1	FC16-16	2.40	1.05	1-5/8	0.86

TUBE O.D.	FEMALE THREAD	PART NO.	L	L1	F	BORE
MILLIMETERS						
6	1/8	MFC6-2	31.78	17.78	14	5.00
6	1/4	MFC6-4	36.78	17.78	19	5.00
6	3/8	MFC6-6	37.78	17.78	22	5.00
6	1/2	MFC6-8	41.78	17.78	27	5.00
8	1/8	MFC8-2	32.49	18.49	15	6.50
8	1/4	MFC8-4	37.49	18.49	19	6.50
8	3/8	MFC8-6	38.49	18.49	22	6.50
10	1/4	MFC10-4	38.60	19.60	19	7.90
10	3/8	MFC10-6	39.60	19.60	22	7.90
10	1/2	MFC10-8	43.60	19.60	27	7.90
12	1/4	MFC12-4	40.81	21.81	22	9.50
12	3/8	MFC12-6	41.81	21.81	22	9.50
12	1/2	MFC12-8	45.81	21.81	27	9.50
16	3/8	MFC16-6	41.81	21.81	24	9.50
16	1/2	MFC16-8	45.81	21.81	27	12.70
20	1/2	MFC20-8	47.83	21.83	30	16.00
20	3/4	MFC20-12	48.83	21.83	35	16.00
22	3/4	MFC22-12	48.81	21.81	35	18.00
25	3/4	MFC25-12	53.76	26.76	35	22.00
25	1	MFC25-16	61.26	26.76	41	22.00

Dimensions for reference only, subject to change without prior notice

BULKHEAD FEMALE CONNECTOR

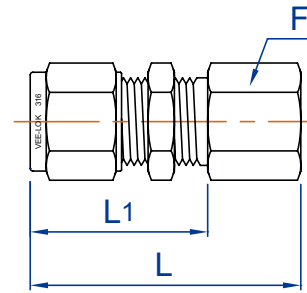

TUBE O.D.	FEMALE THREAD	PART NO.	L	L1	F	Panel Hole Size	Max. Panel Thick.	BORE
INCHES								
1/8	1/8	BFC2-2	1.76	1.23	9/16	21/64	0.50	0.09
1/4	1/8	BFC4-2	1.85	1.31	5/8	29/64	0.40	0.20
1/4	1/4	BFC4-4	2.04	1.31	3/4	29/64	0.40	0.20
3/8	1/4	BFC6-4	2.17	1.44	3/4	37/64	0.44	0.28
1/2	3/8	BFC8-6	2.43	1.65	15/16	49/64	0.50	0.41
1/2	1/2	BFC8-8	2.62	1.65	1-1/16	49/64	0.50	0.41

TUBE O.D.	FEMALE THREAD	PART NO.	L	L1	F	Panel Hole Size	Max. Panel Thick.	BORE
MILLIMETERS								
6	1/8	MBFC6-2	47.20	33.70	16	11.50	10.20	5.00
6	1/4	MBFC6-4	52.00	33.70	19	11.50	10.20	5.00
8	1/8	MBFC8-2	49.60	36.10	18	13.10	11.20	5.00
10	1/4	MBFC10-4	55.20	37.00	22	16.30	11.20	7.10
12	3/8	MBFC12-6	60.90	41.90	24	19.50	12.70	9.50
12	1/2	MBFC12-8	66.40	41.90	27	19.50	12.70	9.50

Dimensions for reference only, subject to change without prior notice

FEMALE ELBOW

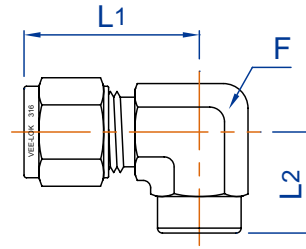

TUBE O.D.	FEMALE THREAD	PART NO.	L1	L2	F	BORE
INCHES						
1/16	1/16	FE1-1	0.71	0.56	1/2	0.052
1/16	1/8	FE1-2	0.81	0.75	9/16	0.052
1/8	1/8	FE2-2	1.07	0.97	1/2	0.09
1/8	1/4	FE2-4	1.26	1.13	11/16	0.09
1/4	1/8	FE4-2	1.07	0.97	1/2	0.20
1/4	1/4	FE4-4	1.25	1.13	11/16	0.20
1/4	3/8	FE4-6	1.31	1.34	13/16	0.20
1/4	1/2	FE4-8	1.38	1.50	1	0.20
5/16	1/8	FE5-2	1.14	1.02	9/16	0.25
5/16	1/4	FE5-4	1.24	1.13	11/16	0.25
3/8	1/8	FE6-2	1.20	0.93	5/8	0.28
3/8	1/4	FE6-4	1.42	1.13	11/16	0.28
3/8	3/8	FE6-6	1.34	1.34	13/16	0.28
3/8	1/2	FE6-8	1.44	1.50	1	0.28
1/2	1/4	FE8-4	1.44	1.07	13/16	0.41
1/2	3/8	FE8-6	1.44	1.34	13/16	0.41
1/2	1/2	FE8-8	1.54	1.50	1	0.41
5/8	3/8	FE10-6	1.55	1.50	1	0.50
5/8	1/2	FE10-8	1.55	1.50	1	0.50
3/4	1/2	FE12-8	1.55	1.50	1	0.61
3/4	3/4	FE12-12	1.89	1.87	1-3/8	0.61
1	3/4	FE16-12	2.00	1.87	1-3/8	0.86

TUBE O.D.	FEMALE THREAD	PART NO.	L1	L2	F	BORE
MILLIMETERS						
6	1/8	MFE6-2	27.20	24.65	1/2	5.00
6	1/4	MFE6-4	31.70	28.80	11/16	5.00
8	1/4	MFE8-4	31.60	28.80	11/16	6.50
10	1/4	MFE10-4	31.90	28.80	11/16	7.90
10	3/8	MFE10-6	34.40	34.00	13/16	7.90
10	1/2	MFE10-8	36.80	38.00	1	7.90
12	1/4	MFE12-4	36.60	27.30	13/16	9.50
12	3/8	MFE12-6	36.60	34.00	13/16	9.50
12	1/2	MFE12-8	39.00	38.00	1	9.50
16	1/2	MFE16-8	39.30	38.00	1	12.70

Dimensions for reference only, subject to change without prior notice

FEMALE RUN TEE

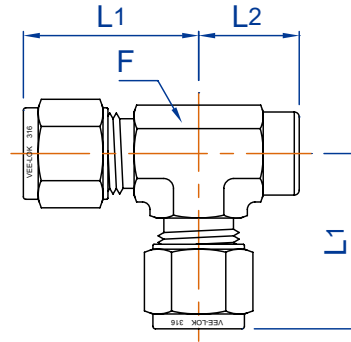

TUBE O.D.	FEMALE THREAD	PART NO.	L1	L2	F	BORE
INCHES						
1/8	1/8	FRT2-2	1.07	0.97	1/2	0.09
1/4	1/8	FRT4-2	1.07	0.97	1/2	0.20
1/4	1/4	FRT4-4	1.18	1.13	11/16	0.20
3/8	1/4	FRT6-4	1.23	1.13	11/16	0.28
1/2	3/8	FRT8-6	1.46	1.38	7/8"	0.38
1/2	1/2	FRT8-8	1.56	1.44	1-1/16	0.41
3/4	3/4	FRT12-12	1.89	1.87	1-3/8	0.61
1	3/4	FRT16-12	2.00	1.87	1-3/8	0.86

TUBE O.D.	FEMALE THREAD	PART NO.	L1	L2	F	BORE
MILLIMETERS						
6	1/8	MFRT6-2	27.20	24.70	1/2	5.00
6	1/4	MFRT6-4	29.80	28.80	11/16	5.00
8	1/8	MFRT8-2	29.50	24.00	5/8	6.50
10	1/4	MFRT10-4	31.60	28.80	11/16	7.90
12	1/4	MFRT12-4	36.60	27.30	13/16	9.50
12	3/8	MFRT12-6	37.20	35.00	7/8"	9.50
12	1/2	MFRT12-8	39.70	36.50	1-1/16	9.50
16	1/2	MFRT16-8	40.00	36.50	1-1/16	12.70

Dimensions for reference only, subject to change without prior notice

FEMALE BRANCH TEE

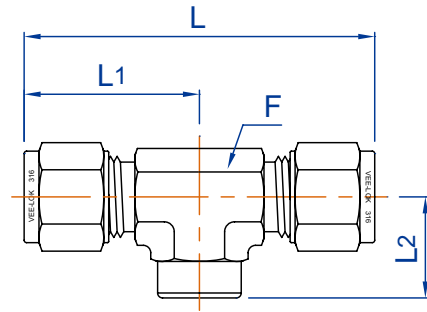

TUBE O.D.	FEMALE THREAD	PART NO.	L	L1	L2	F	BORE
INCHES							
1/8	1/8	FBT2-2	2.14	1.07	0.97	1/2	0.09
1/4	1/8	FBT4-2	2.14	1.07	0.97	1/2	0.20
1/4	1/4	FBT4-4	2.36	1.18	1.13	11/16	0.20
3/8	1/4	FBT6-4	2.46	1.23	1.13	11/16	0.28
1/2	1/4	FBT8-4	2.88	1.44	1.07	13/16	0.41
1/2	3/8	FBT8-6	2.92	1.46	1.38	7/8"	0.41
1/2	1/2	FBT8-8	3.12	1.56	1.44	1-1/16	0.41
5/8	1/2	FBT10-8	3.14	1.57	1.44	1-1/16	0.50
3/4	3/4	FBT12-12	3.78	1.89	1.87	1-3/8	0.61
1	3/4	FBT16-12	4.00	2.00	1.87	1-3/8	0.86

TUBE O.D.	FEMALE THREAD	PART NO.	L	L1	L2	F	BORE
MILLIMETERS							
6	1/8	MFBT6-2	54.40	27.20	24.70	1/2	5.00
6	1/4	MFBT6-4	60.00	30.00	28.80	11/16	5.00
8	1/8	MFBT8-2	59.00	29.50	24.00	5/8	6.50
10	1/4	MFBT10-4	64.00	32.00	28.80	11/16	7.90
12	1/4	MFBT12-4	73.20	36.60	27.30	13/16	9.50
12	3/8	MFBT12-6	74.40	37.20	35.00	7/8"	9.50
12	1/2	MFBT12-8	79.40	39.70	36.50	1-1/16	9.50
16	1/2	MFBT16-8	80.00	40.00	36.50	1-1/16	12.70

Dimensions for reference only, subject to change without prior notice

UNION TEE

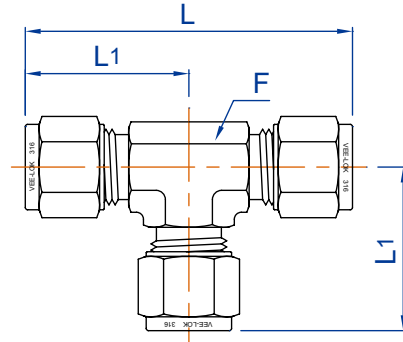

TUBE O.D.	PART NO.	L	L1	F	BORE
INCHES					
1/16	UT1	1.42	0.71	1/2	0.052
1/8	UT2	2.14	1.07	1/2	0.09
1/4	UT4	2.14	1.07	1/2	0.20
5/16	UT5	2.32	1.16	5/8	0.25
3/8	UT6	2.40	1.20	5/8	0.28
1/2	UT8	2.88	1.44	13/16	0.41
5/8	UT10	3.14	1.57	1-1/16	0.50
3/4	UT12	3.14	1.57	1-1/16	0.61
1	UT16	4.00	2.00	1-3/8	0.70

TUBE O.D.	PART NO.	L	L1	F	BORE
MILLIMETERS					
6	MUT6	54.40	27.20	1/2	5.00
8	MUT8	59.00	29.50	5/8	6.50
10	MUT10	63.20	31.60	11/16	7.90
12	MUT12	73.20	36.60	13/16	9.50
14	MUT14	80.00	40.00	1-1/16	11.10
15	MUT15	80.00	40.00	1-1/16	11.90
16	MUT16	80.00	40.00	1-1/16	12.70
18	MUT18	80.00	40.00	1-1/16	15.00
20	MUT20	95.00	47.50	1-3/8	16.00
22	MUT22	95.00	47.50	1-3/8	18.00
25	MUT25	101.40	50.70	1-3/8	22.00

Dimensions for reference only, subject to change without prior notice

UNION

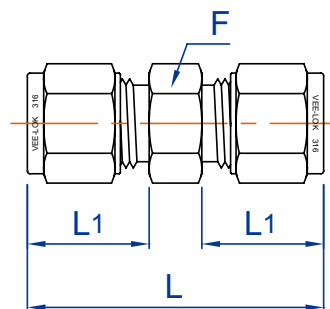

TUBE O.D.	PART NO.	L	L1	F	BORE
INCHES					
1/16	U1	0.99	0.43	5/16	0.052
1/8	U2	1.39	0.60	7/16	0.094
1/4	U4	1.62	0.70	1/2	0.196
5/16	U5	1.70	0.73	9/16	0.255
3/8	U6	1.77	0.76	5/8	0.279
1/2	U8	2.02	0.87	13/16	0.409
5/8	U10	2.05	0.87	15/16	0.500
3/4	U12	2.11	0.87	1-1/16	0.610
1	U16	2.57	1.05	1-3/8	0.866

TUBE O.D.	PART NO.	L	L1	F	BORE
MILLIMETERS					
6	MU6	41.20	17.70	14	5.00
8	MU8	43.20	18.60	15	6.50
10	MU10	46.20	19.50	18	7.90
12	MU12	51.20	22.00	22	9.50
14	MU14	52.00	22.00	24	11.10
15	MU15	52.00	22.00	24	11.90
16	MU16	52.00	22.00	24	12.70
18	MU18	53.50	22.00	27	15.00
20	MU20	55.00	22.00	30	16.00
22	MU22	55.00	22.00	30	18.00
25	MU25	65.10	26.50	35	22.00

Dimensions for reference only, subject to change without prior notice

REDUCING UNION

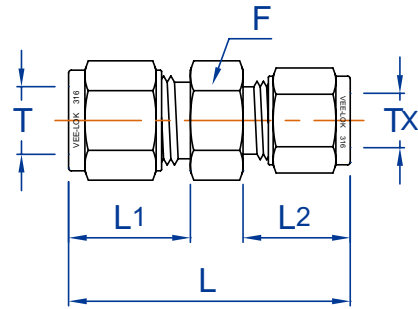

T TUBE O.D.	TX TUBE O.D.	PART NO.	L	L1	L2	F	BORE
INCHES							
1/8	1/16	RU2-1	1.21	0.60	0.43	7/16	0.052
1/4	1/16	RU4-1	1.38	0.70	0.43	1/2	0.052
1/4	1/8	RU4-2	1.52	0.97	0.70	1/2	0.09
5/16	1/8	RU5-2	1.58	1.03	0.73	9/16	0.09
5/16	1/4	RU5-4	1.67	1.08	0.73	9/16	0.20
3/8	1/8	RU6-2	1.61	1.06	0.76	5/8	0.09
3/8	1/4	RU6-4	1.71	1.13	0.76	5/8	0.20
3/8	5/16	RU6-5	1.75	1.16	0.76	5/8	0.25
1/2	1/8	RU8-2	1.75	1.09	0.87	13/16	0.09
1/2	1/4	RU8-4	1.85	1.16	0.87	13/16	0.20
1/2	3/8	RU8-6	1.91	1.22	0.87	13/16	0.28
5/8	3/8	RU10-6	1.94	1.25	0.87	15/16	0.28
5/8	1/2	RU10-8	2.05	1.25	0.87	15/16	0.41
3/4	1/4	RU12-4	1.95	1.25	0.87	1-1/16	0.20
3/4	3/8	RU12-6	2.00	1.31	0.87	1-1/16	0.28
3/4	1/2	RU12-8	2.11	1.31	0.87	1-1/16	0.41
3/4	5/8	RU12-10	2.11	1.31	0.87	1-1/16	0.50
1	1/2	RU16-8	2.39	1.50	1.05	1-3/8	0.41
1	3/4	RU16-12	2.39	1.50	1.05	1-3/8	0.61

T TUBE O.D.	TX TUBE O.D.	PART NO.	L	L1	L2	F	BORE
MILLIMETERS							
8	6	MMRU8-6	42.40	18.60	17.70	15	5.00
10	6	MMRU10-6	44.50	19.50	17.70	18	5.00
10	8	MMRU10-8	44.50	19.50	18.60	18	6.50
12	6	MMRU12-6	47.00	22.00	17.70	22	5.00
12	8	MMRU12-8	47.80	22.00	18.60	22	6.50
12	10	MMRU12-10	48.70	22.00	19.50	22	7.90
16	10	MMRU16-10	49.50	22.00	19.50	24	7.90
16	12	MMRU16-12	52.00	22.00	22.00	24	9.50
18	12	MMRU18-12	53.50	22.00	22.00	27	9.50
25	18	MMRU25-18	60.50	26.50	22.00	35	15.00
25	20	MMRU25-20	62.30	26.50	22.00	35	16.00

Dimensions for reference only, subject to change without prior notice

BULKHEAD UNION

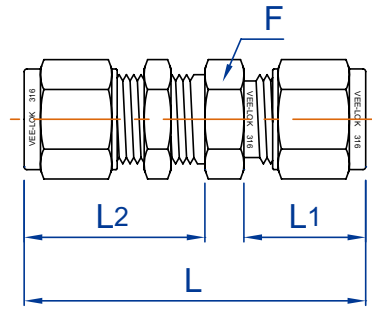

TUBE O.D.	PART NO.	L	L1	L2	F	Panel Hole Size	Max. Panel Thick.	BORE
INCHES								
1/16	BU1	1.23	0.43	0.68	5/16	13/64	0.12	0.052
1/8	BU2	2.02	0.60	1.23	1/2	21/64	1/2	0.09
1/4	BU4	2.27	0.70	1.31	5/8	29/64	17/32	0.20
5/16	BU5	2.40	0.73	1.42	11/16	33/64	9/16	0.25
3/8	BU6	2.46	0.76	1.44	3/4	37/64	9/16	0.28
1/2	BU8	2.80	0.87	1.65	15/16	49/64	19/32	0.41
5/8	BU10	2.86	0.87	1.68	1-1/16	57/64	19/32	0.50
3/4	BU12	3.11	0.87	1.87	1-3/16	1-1/64	25/32	0.61
1	BU16	3.78	1.05	2.27	1-5/8	1-21/64	15/16	0.86

TUBE O.D.	PART NO.	L	L1	L2	F	Panel Hole Size	Max. Panel Thick.	BORE
MILLIMETERS								
6	MBU6	57.90	17.70	33.70	16	11.50	10.20	5.00
8	MBU8	61.00	18.60	36.00	18	13.10	11.20	6.50
10	MBU10	63.60	19.50	37.00	22	16.30	11.20	7.90
12	MBU12	71.00	22.00	41.90	24	19.50	12.70	9.50
15	MBU15	72.50	22.00	42.60	27	22.50	12.70	11.90
16	MBU16	72.60	22.00	42.60	27	22.50	12.70	12.70
18	MBU18	78.90	22.00	47.40	30	26.00	16.80	15.00
20	MBU20	88.20	22.00	51.00	35	29.00	19.00	16.00
25	MBU25	95.80	26.50	54.40	41	33.80	24.00	22.00

Dimensions for reference only, subject to change without prior notice

UNION ELBOW

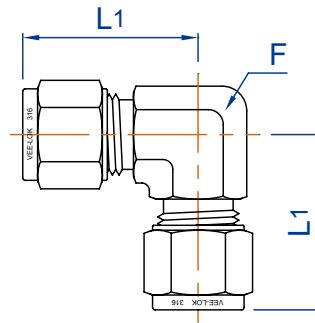

TUBE O.D.	PART NO.	L1	F	BORE
INCHES				
1/16	UE1	0.71	1/2	0.052
1/8	UE2	1.07	1/2	0.09
1/4	UE4	1.07	1/2	0.20
5/16	UE5	1.14	9/16	0.25
3/8	UE6	1.20	5/8	0.28
1/2	UE8	1.44	13/16	0.41
5/8	UE10	1.57	1	0.50
3/4	UE12	1.57	1	0.61
1	UE16	2.00	1-3/8	0.86

TUBE O.D.	PART NO.	L1	F	BORE
MILLIMETERS				
6	MUE6	27.20	1/2	5.00
8	MUE8	29.10	9/16	6.50
10	MUE10	31.60	11/16	7.90
12	MUE12	36.60	13/16	9.50
14	MUE14	40.00	1	11.10
15	MUE15	40.00	1	11.90
16	MUE16	40.00	1	12.70
18	MUE18	40.00	1	15.00
20	MUE20	47.50	1-3/8	16.00
22	MUE22	47.50	1-3/8	18.00
25	MUE25	50.70	1-3/8	22.00

Dimensions for reference only, subject to change without prior notice

CROSS UNION

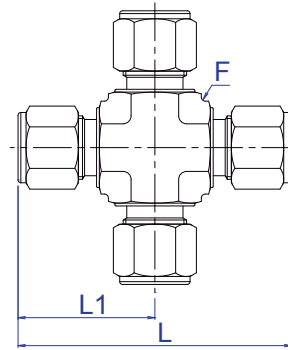

TUBE O.D.	PART NO.	L	L1	F	BORE
-----------	----------	---	----	---	------

INCHES

1/8	CU2	2.14	1.07	1/2	0.09
1/4	CU4	2.14	1.07	1/2	0.20
3/8	CU6	2.38	1.19	5/8	0.28
1/2	CU8	2.88	1.44	13/16	0.41

TUBE O.D.	PART NO.	L	L1	F	BORE
-----------	----------	---	----	---	------

MILLIMETERS

6	MCU6	54.40	27.20	1/2	5.00
8	MCU8	60.60	30.30	5/8	6.50
10	MCU10	68.80	34.40	13/16	7.90
12	MCU12	73.20	36.60	13/16	9.50

Dimensions for reference only, subject to change without prior notice

REDUCER

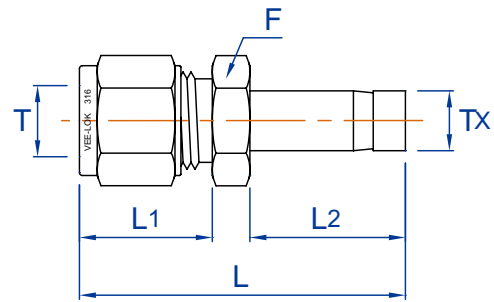

T TUBE O.D.	TX TUBE O.D.	PART NO.	L	L1	L2	F	BORE
INCHES							
1/16	1/8	R1-2	1.10	0.43	0.53	5/16	0.080
1/16	1/4	R1-4	1.24	0.43	0.63	7/16	0.170
1/8	1/8	R2-2	1.36	0.59	0.55	7/16	0.078
1/8	1/4	R2-4	1.45	0.59	0.64	7/16	0.169
1/4	1/8	R4-2	1.47	0.69	0.55	1/2	0.078
1/4	1/4	R4-4	1.56	0.69	0.64	1/2	0.169
1/4	3/8	R4-6	1.60	0.69	0.69	1/2	0.267
1/4	1/2	R4-8	1.80	0.69	0.91	9/16	0.370
3/8	1/4	R6-4	1.64	0.75	0.65	5/8	0.169
3/8	3/8	R6-6	1.68	0.75	0.69	5/8	0.267
3/8	1/2	R6-8	1.90	0.75	0.91	5/8	0.370
1/2	1/4	R8-4	1.77	0.86	0.65	13/16	0.169
1/2	3/8	R8-6	1.82	0.86	0.69	13/16	0.267
1/2	3/4	R8-12	2.10	0.86	0.97	13/16	0.570
3/4	1/2	R12-8	2.07	0.86	0.91	1-1/16	0.370

Dimensions for reference only, subject to change without prior notice

REDUCER

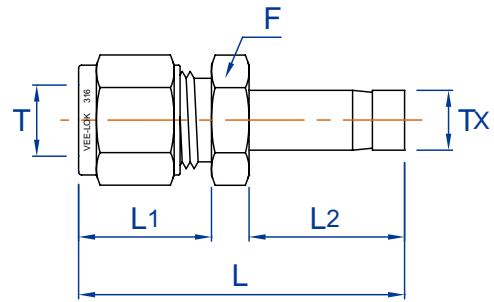

T TUBE O.D.	TX TUBE O.D.	PART NO.	L	L1	L2	F	BORE
MILLIMETERS							
6	8	MR6-8	41.10	17.80	16.70	14	5.60
6	10	MR6-10	42.00	17.80	17.60	14	7.50
6	12	MR6-12	47.40	17.80	23.00	14	8.80
8	6	MR8-6	41.50	18.50	16.40	15	4.00
8	10	MR8-10	42.70	18.50	17.60	15	7.50
10	6	MR10-6	43.00	19.60	16.40	18	4.00
10	8	MR10-8	43.30	19.60	16.70	18	5.60
10	12	MR10-12	49.60	19.60	23.00	18	8.80
12	6	MR12-6	46.20	21.80	16.40	22	4.00
12	8	MR12-8	46.50	21.80	16.70	22	5.60
12	10	MR12-10	47.40	21.80	17.60	22	7.50
12	16	MR12-16	54.40	21.80	24.60	22	12.70
12	18	MR12-18	54.40	21.80	24.60	22	14.00
16	12	MR16-12	53.30	21.80	23.00	24	8.80
18	12	MR18-12	53.30	21.80	23.00	27	8.80
18	16	MR18-16	55.40	21.80	24.60	27	12.70
18	20	MR18-20	57.00	21.80	26.20	27	15.50
18	25	MR18-25	62.60	21.80	31.80	27	20.60
20	16	MR20-16	56.40	21.80	24.60	30	12.70
20	18	MR20-18	56.40	21.80	24.60	30	14.00
20	25	MR20-25	63.60	21.80	31.80	30	20.60
22	18	MR22-18	56.40	21.80	24.60	30	14.00
22	20	MR22-20	58.00	21.80	26.20	30	15.50
25	12	MR25-12	59.70	26.80	23.00	35	8.80
25	18	MR25-18	63.90	26.80	24.60	35	14.00
25	20	MR25-20	65.50	26.80	26.20	35	15.50

Dimensions for reference only, subject to change without prior notice

MALE ADAPTER

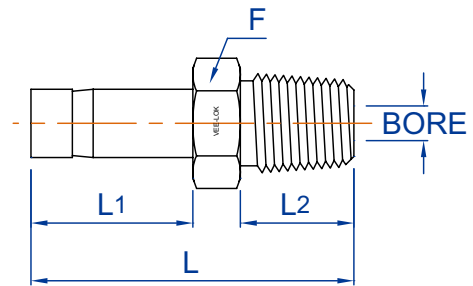

TUBE O.D.	MALE THREAD	PART NO.	L	L1	L2	F	BORE
INCHES							
1/16	1/8	MA1-2	1.00	0.38	0.38	7/16	0.031
1/8	1/8	MA2-2	1.15	0.56	0.38	7/16	0.078
1/8	1/4	MA2-4	1.35	0.56	0.56	9/16	0.078
1/4	1/8	MA4-2	1.24	0.65	0.38	7/16	0.169
1/4	1/4	MA4-4	1.44	0.65	0.56	9/16	0.169
1/4	3/8	MA4-6	1.46	0.65	0.56	11/16	0.169
1/4	1/2	MA4-8	1.73	0.65	0.75	7/8	0.169
5/16	1/8	MA5-2	1.26	0.66	0.38	7/16	0.216
5/16	1/4	MA5-4	1.46	0.66	0.56	9/16	0.216
3/8	1/8	MA6-2	1.37	0.69	0.38	7/16	0.267
3/8	1/4	MA6-4	1.46	0.69	0.56	9/16	0.267
3/8	3/8	MA6-6	1.51	0.69	0.56	11/16	0.267
3/8	1/2	MA6-8	1.73	0.69	0.75	7/8	0.267
1/2	1/4	MA8-4	1.67	0.91	0.56	9/16	0.370
1/2	3/8	MA8-6	1.74	0.91	0.56	11/16	0.370
1/2	1/2	MA8-8	1.96	0.91	0.75	7/8	0.370
5/8	1/2	MA10-8	2.02	0.97	0.75	7/8	0.468
3/4	1/2	MA12-8	2.06	0.97	0.75	7/8	0.570
3/4	3/4	MA12-12	2.06	0.97	0.75	1-1/16	0.570
1	3/4	MA16-12	2.34	1.25	0.75	1-1/16	0.826
1	1	MA16-16	2.70	1.25	0.94	1-3/16	0.826

TUBE O.D.	MALE THREAD	PART NO.	L	L1	L2	F	A	BORE
MILLIMETERS								
6	1/8	MMA6-2	32.10	16.40	9.70	11	4.00	4.00
6	1/4	MMA6-4	37.10	16.40	14.20	14	4.00	4.00
8	1/4	MMA8-4	37.40	16.70	14.20	14	6.40	5.60
8	3/8	MMA8-6	37.90	16.70	14.20	18	6.40	5.60
10	1/4	MMA10-4	38.30	17.60	14.20	14	7.10	7.50
10	3/8	MMA10-6	38.80	17.60	14.20	18	7.50	7.50
10	1/2	MMA10-8	44.70	17.60	19.10	22	7.50	7.50
12	1/4	MMA12-4	44.20	23.00	14.20	14	7.10	8.80
12	1/2	MMA12-8	50.10	23.00	19.10	22	9.10	8.80
16	1/2	MMA16-8	51.70	24.60	19.10	22	12.70	12.70
18	1/2	MMA18-8	51.70	24.60	19.10	22	12.70	14.00
18	3/4	MMA18-12	52.70	24.60	19.10	27	14.00	14.00
20	3/4	MMA20-12	53.50	26.20	19.10	27	15.10	15.50
25	1	MMA25-16	69.20	31.80	23.90	35	19.80	20.60

Dimensions for reference only, subject to change without prior notice

FEMALE ADAPTER

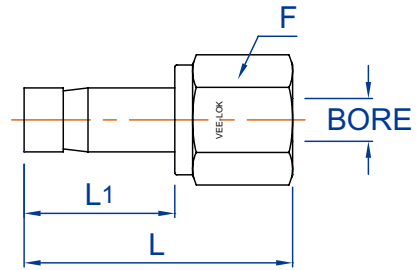

TUBE O.D.	FEMALE THREAD	PART NO.	L	L1	F	BORE
INCHES						
1/16	1/8	FA1-2	1.070	0.340	9/16	0.031
1/8	1/8	FA2-2	1.125	0.555	9/16	0.078
1/8	1/4	FA2-4	1.322	0.555	3/4	0.078
1/4	1/8	FA4-2	1.216	0.645	9/16	0.169
1/4	1/4	FA4-4	1.413	0.645	3/4	0.169
1/4	3/8	FA4-6	1.452	0.645	7/8	0.169
1/4	1/2	FA4-8	1.590	0.645	1-1/16	0.169
5/16	1/4	FA5-4	1.429	0.661	3/4	0.216
3/8	1/8	FA6-2	1.263	0.692	9/16	0.267
3/8	1/4	FA6-4	1.460	0.692	3/4	0.267
3/8	3/8	FA6-6	1.500	0.692	7/8	0.267
3/8	1/2	FA6-8	1.637	0.692	1-1/16	0.267
1/2	1/4	FA8-4	1.673	0.905	3/4	0.370
1/2	3/8	FA8-6	1.712	0.905	7/8	0.370
1/2	1/2	FA8-8	1.850	0.905	1-1/16	0.370
5/8	1/2	FA10-8	1.917	0.972	1-1/16	0.468
3/4	1/2	FA12-8	1.917	0.972	1-1/16	0.570
3/4	3/4	FA12-12	2.035	0.972	1-3/8	0.570
3/4	1	FA12-16	2.133	0.972	1-5/8	0.570
1	3/4	FA16-12	2.314	1.251	1-3/8	0.826
1	1	FA16-16	2.610	1.251	1-5/8	0.826

TUBE O.D.	FEMALE THREAD	PART NO.	L	L1	F	A	BORE
MILLIMETERS							
6	1/8	MFA6-2	30.40	16.40	14	4.00	4.00
6	1/4	MFA6-4	35.40	16.40	19	4.00	4.00
8	1/4	MFA8-4	35.70	16.70	19	6.40	5.60
10	1/4	MFA10-4	36.60	17.60	19	7.50	7.50
10	3/8	MFA10-6	37.60	17.60	22	7.50	7.50
10	1/2	MFA10-8	41.60	17.60	27	7.50	7.50
12	1/4	MFA12-4	42.00	23.00	19	9.10	8.80
12	3/8	MFA12-6	43.00	23.00	22	9.10	8.80
12	1/2	MFA12-8	47.00	23.00	27	9.10	8.80
16	1/2	MFA16-8	48.60	24.60	27	12.70	12.70
18	3/4	MFA18-12	51.60	24.60	35	14.00	14.00
20	1/2	MFA20-8	50.20	26.20	27	15.00	15.50
20	3/4	MFA20-12	53.20	26.20	35	15.10	15.50
25	1	MFA25-16	66.30	31.80	41	19.80	20.60

Dimensions for reference only, subject to change without prior notice

NUT

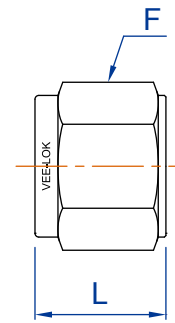

TUBE O.D.	PART NO.	L	F
INCHES			
1/8	N2	0.47	7/16
1/4	N4	0.50	9/16
5/16	N5	0.53	5/8
3/8	N6	0.56	11/16
1/2	N8	0.69	7/8
5/8	N10	0.69	1
3/4	N12	0.69	1-3/16
1	N16	0.81	1-1/2

TUBE O.D.	PART NO.	L	F
MILLIMETERS			
6	MN6	12.70	14
8	MN8	13.50	16
10	MN10	15.10	19
12	MN12	17.50	22
14	MN14	17.50	25
15	MN15	17.50	25
16	MN16	17.50	25
18	MN18	17.50	30
20	MN20	17.50	32
22	MN22	17.50	32
25	MN25	20.60	38

Dimensions for reference only, subject to change without prior notice

BACK FERRULE

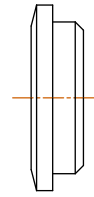

TUBE O.D.	PART NO.
INCHES	
1/8	BF2
1/4	BF4
5/16	BF5
3/8	BF6
1/2	BF8
5/8	BF10
3/4	BF12
1	BF16

TUBE O.D.	PART NO.
MILLIMETERS	
6	MBF6
8	MBF8
10	MBF10
12	MBF12
14	MBF14
15	MBF15
16	MBF16
18	MBF18
20	MBF20
22	MBF22
25	MBF25

Dimensions for reference only, subject to change without prior notice

FRONT FERRULE



TUBE O.D.	PART NO.
INCHES	
1/8	FF2
1/4	FF4
5/16	FF5
3/8	FF6
1/2	FF8
5/8	FF10
3/4	FF12
1	FF16

TUBE O.D.	PART NO.
MILLIMETERS	
6	MFF6
8	MFF8
10	MFF10
12	MFF12
14	MFF14
15	MFF15
16	MFF16
18	MFF18
20	MFF20
22	MFF22
25	MFF25

Dimensions for reference only, subject to change without prior notice

PLUG

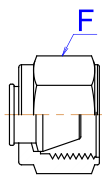

CAP

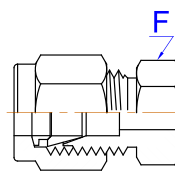

TUBE O.D.	PART NO.	F
INCHES		
1/8	P2	7/16
1/4	P4	9/16
5/16	P5	5/8
3/8	P6	11/16
1/2	P8	7/8
5/8	P10	1
3/4	P12	1-3/16
1	P16	1-1/2

TUBE O.D.	PART NO.	F
INCHES		
1/8	CP2	7/16
1/4	CP4	1/2
5/16	CP5	9/16
3/8	CP6	5/8
1/2	CP8	7/8
5/8	CP10	15/16
3/4	CP12	1-1/16
1	CP16	1-3/8

TUBE O.D.	PART NO.	F
MILLIMETERS		
6	MP6	14
8	MP8	16
10	MP10	19
12	MP12	22
14	MP14	25
15	MP15	25
16	MP16	25
18	MP18	30
20	MP20	32
22	MP22	32
25	MP25	38

TUBE O.D.	PART NO.	F
MILLIMETERS		
6	MCP6	14
8	MCP8	15
10	MCP10	18
12	MCP12	22
14	MCP14	24
15	MCP15	24
16	MCP16	24
18	MCP18	27
20	MCP20	30
22	MCP22	30
25	MCP25	35

Dimensions for reference only, subject to change without prior notice



Vertex Co., Ltd.

3F, No.3, Lane 551, Sec. 1, Wanshou Rd.,
Gueishan Township, Taoyuan County 33351,
Taiwan

Tel: +886 2 8200 3813

Fax: +886 2 8200 3817

vertex.jo@msa.hinet.net

